

EMD1211-D Driver Amplifier

DC-20 GHz GaAs PHEMT MMIC Distributed Amplifier

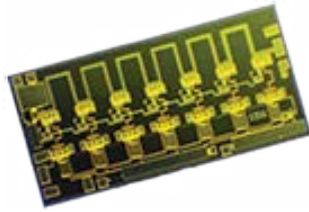

EclipseMDI Products EMD1211-D is an GaAs MMIC general purpose driver amplifier in die form operating from DC to 20 GHz. This MMIC amplifier is ideal for applications that requires a typical output power of +30.5 dBm @ 10 GHz while requiring only 290mA from a +8.0 volt supply. Gain flatness of this device is typically < +1.0dB from DC to 10 GHz.

Technical Characteristics

Product Features	
10.0 dB Gain @ 10 GHz	
+30.0dBm Min. Psat Output Power @ 2 GHz	
+12.0V @ 300 mA Typical Supply Voltage	
Typical Return Loss (dB): 14-18dB	
Low Noise Figure: 6.5dB	

Max. Ratings	
RF Input Power:	+18.0 dBm
Drain Voltage (Vdd):	+8.0 VDC
Gate Voltage (Vgg):	-2.0 to 0 VDC
Max. T _j 85° C:	+110°C
Storage Temperature:	-55 to +150°
Operating Temperature:	-40 to +85°

Electrical Specifications @ +25°C, Vdd= 8.0, Ids= 290mA

Parameters	Freq. (GHz)	Min.	Typical	Max.	Units
Gain	2.0		13.2		dB
	8.0		13.0		dB
	14.0		13.5		dB
	20.0		12.5		dB
Gain Flatness	DC to 10.0 GHz		+/- 0.80	+/- 1.0	dB
	10.0 to 20.0		+/- 0.50	+/- 0.80	dB
Gain Variation Over Temperature				.02	dB/°C
Noise Figure			6.5		dB
Input Return Loss			14.0		dB
Output Return Loss			18.0		dB
1dB Compression Point	2.0-6.0		28.0		dBm
	6.0-8.0		28.0		dBm
	8.0-14.0		28.5		dBm
	14.0-20.0		26.0		dBm
Saturated Output Power	2.0-6.0		31.0		dBm
	6.0-8.0		30.5		dBm
	8.0-14.0		28.5		dBm
	14.0-20.0		28.0		dBm
3rd Order Intercept Point	2.0		38.0		dBm
	8.0		38.0		dBm
	14.0		34.0		dBm
	20.0		32.0		dBm

About EclipseMDI

ECLIPSE MDI is located in San Jose, California. ECLIPSE has been developing high performance analog semiconductors for use in wireless radio frequency (RF), microwave, and millimeter wave for commercial and industrial applications. ECLIPSE has formed a strategic alliances - with foundries that feature leading state-of-the-art process technologies and with manufacturing facilities for high-volume production of innovative RFIC's.

EMD1211-D Driver Amplifier

DC-20 GHz GaAs PHEMT MMIC Distributed Amplifier



Outline Drawing

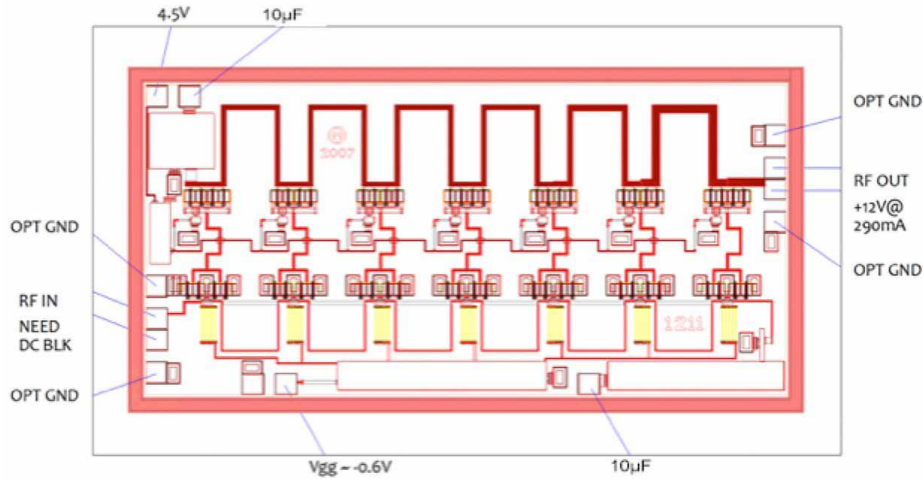

Functional block diagram

Recommended PCB layout

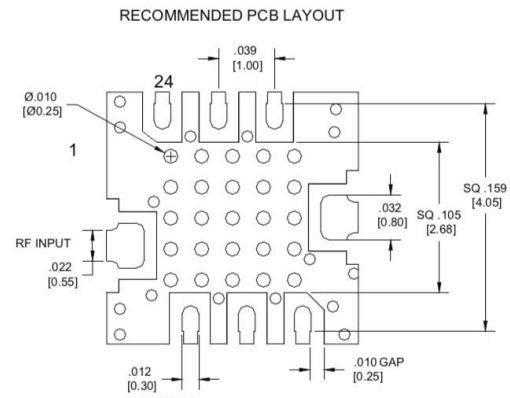
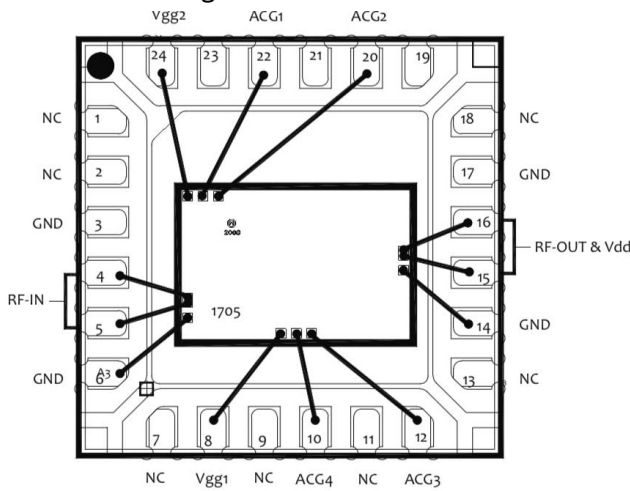

NOTES:
 1. MATERIAL: ROGERS 4350, 10 MIL THICK
 2. DIMENSIONS ARE IN INCHES[MM]

Application Circuit

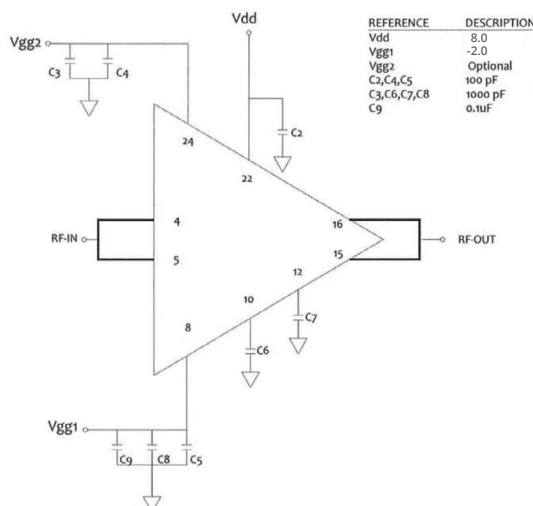

NOTE: Adjust Vgg1 to between -2 to 0 volts to achieve I_{ds}: 290mA typical