

# J16026 Double Balanced Mixer

16.0 to 26.0 GHz

## Technical Characteristics



Product Features
Multi-octave bandwidth
Broad frequency - input and output
Wide DC to IF frequency response
Low conversion loss
High port-to-port isolation

Maximum Ratings	
Storage Temperature	-65 to +150°C
Operating Temperature Peak	-55 to +125°C
Peak Input Power For Any Single Port	+23dBm Peak
Peak Input Power For Any Port	+26dBm peak
Peak Input Current @ +25° C	100mA

Parameters	Freq. (GHz)	Minimum	Typical	Maximum	Units	Conditions
<b>Conversion Loss</b>						
RF Input	16.0 to 26.0					
LO Input	16.0 to 26.0		7.5	9.5	dB	IF = 1000 MHz
IF Output	DC to 4.0		8.5	10.5	dB	IF = 4000 MHz
Conversion Flatness						
<b>Isolation</b>						
LO-RF	16.0 to 26.0	30.0	40.0		dB	LO = 16.0 to 24.0
LO-IF	16.0 to 26.0	20.0	28.0		dB	LO = 16.0 to 21.0
RF-IF			35.0		dB	
VSWR						
<b>1dB Comp.Point</b>						
J16026L			0.0		dBm	
J16026M			4.0		dBm	
<b>LO Drive</b>						
J16026L		7.0	9.0	10.0	dBm	
J16026M		9.0	10.0	13.0	dBm	
<b>Input TOIP</b>						
J16026L			11.0		dBm	
J16026M			14.0		dBm	

### NOTES:

1. Measured in a 50 ohm system with nominal LO drive and downconverter application only, unless otherwise specified. The I-port frequency range extends to DC for phase detection, pulse modulation, or attenuator applications. I-port VSWR degrades from a 50 Ω system at LO-IF frequencies.

2. Typical values are measured at +25°C and are not guaranteed.

### Package outline Z

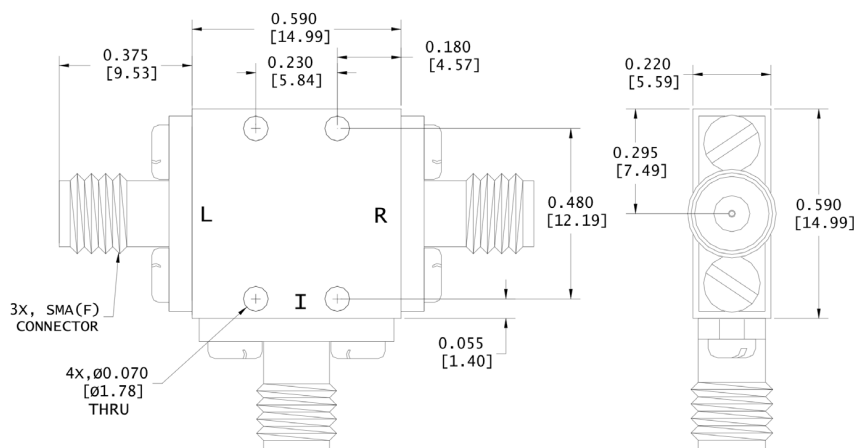

### Product Export Classification

ECCN: EAR 99 (unless otherwise specified)  
HTS: 8541.10.0060



1

DISCLAIMER: Subject to change without notice.

# J16026 Double Balanced Mixer

16.0 to 26.0

## Outline Drawings 1 of 2

### Coaxial Package outline 'B'

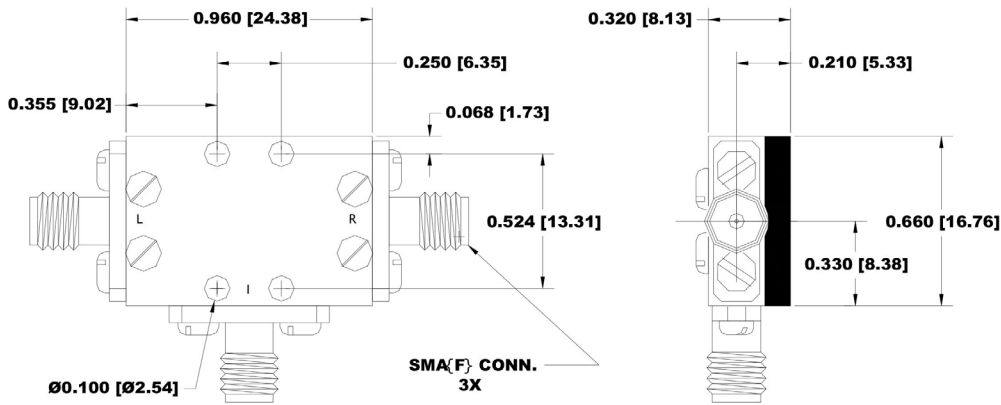

### Coaxial Package outline 'L'

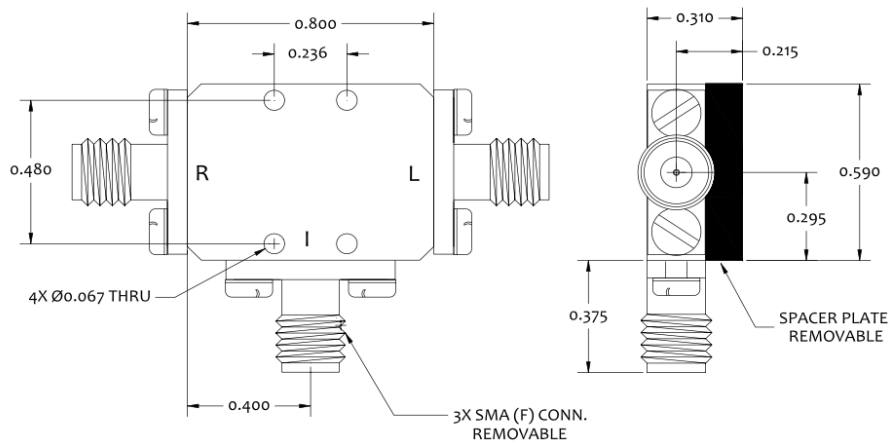

### Coaxial Package outline 'C'

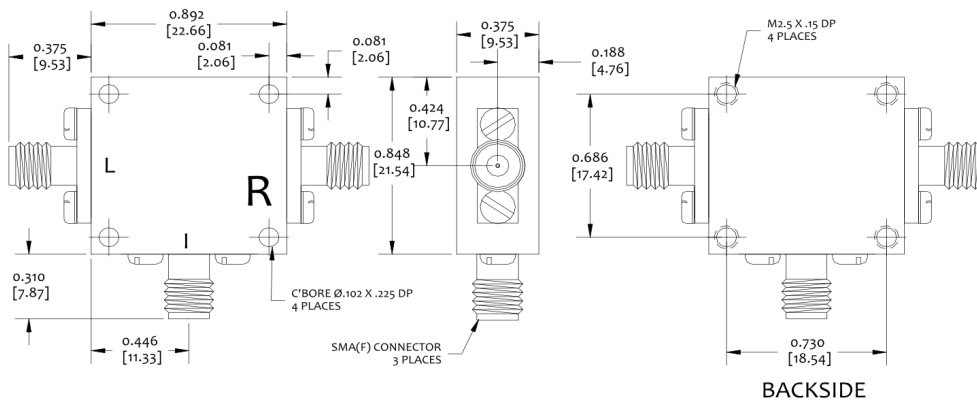

# J16026 Double Balanced Mixer

16.0 to 26.0

## Outline Drawings 2 of 2

### Drop in Package outline 'E1'

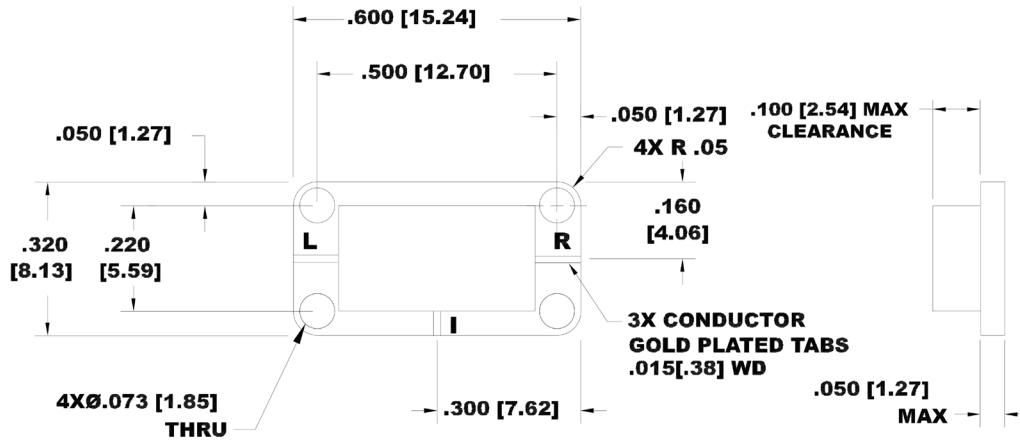

### Drop in Package outline 'F1'

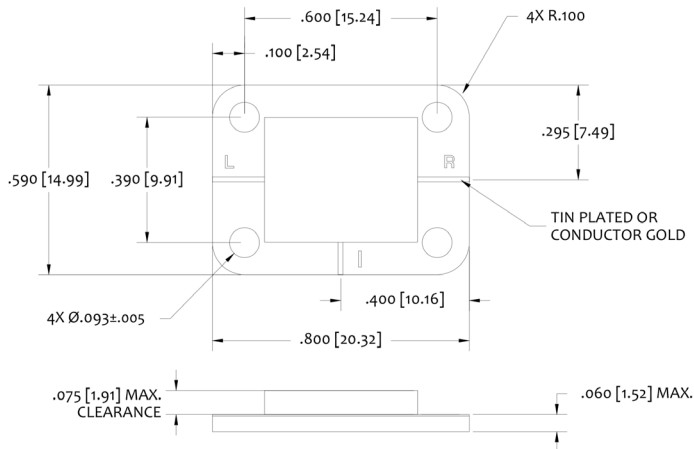

### Drop in Package outline 'ZX'

